

# Care and Maintenance

**UV INKJET PRINTER**

***JFX550-2513***

***JFX600-2513***

**Requests for Care and Maintenance**

You can also download the latest manual from official website.

**MIMAKI ENGINEERING CO., LTD.**

<https://mimaki.com/>

D203595-12

Original instructions

# TABLE OF CONTENTS

---

Introduction .....	3
To Ensure Safe Use .....	4
Symbols .....	4

## Maintenance

1. Maintenance Precautions .....	6
2. Maintenance Timing .....	7
Tools Required for Maintenance .....	7
3. Performing Maintenance .....	8
Ink Maintenance .....	8
Wiper Cleaning .....	8
Cap Rubber Cleaning .....	10
Station Area Cleaning .....	10
NCU Cleaning .....	11
Carriage Underside Cleaning .....	12
Waste Ink Draining Channel Cleaning .....	14
Table Cleaning .....	15
Exterior Cleaning (e.g., cover, Y-bar, ) .....	15
4. Consumable Item Replacement .....	17
Wiper Replacement .....	17
Carriage Filter Replacement .....	18
Flushing Filter Replacement .....	19
NCU Ink Pad Replacement .....	19
Bottle Ink Wipe Filter Replacement .....	20
Waste Ink Tank Replacement .....	21
Refilling Cooling Water (Mixed With Antifreeze) .....	22

# Introduction

Thank you for purchasing the UV-LED curable inkjet printer JFX550-2513, JFX600-2513.

Read the care and maintenance ("this document" hereinafter) thoroughly and make sure you understand its contents to ensure safe and correct use of the product.

Please note that the illustrations contained in this document are intended to show functions, procedures, or operations and may sometimes differ slightly from the actual machine.

Unauthorized reproduction of any portion of this document is strictly prohibited.

© 2021 MIMAKI ENGINEERING Co., Ltd.









## ● DISCLAIMERS

- MIMAKI ENGINEERING REJECTS ALL LIABILITY FOR DAMAGE ARISING DIRECTLY OR INDIRECTLY FROM THE USE OF THE JFX550-2513, JFX600-2513 ("THIS MACHINE" HEREINAFTER), WHETHER OR NOT THE PRODUCT IS FAULTY.
- MIMAKI ENGINEERING REJECTS ALL LIABILITY FOR DAMAGE, DIRECT OR INDIRECT, TO MATERIALS CREATED WHILE USING THIS MACHINE.
- USING THIS MACHINE IN CONJUNCTION WITH DEVICES OTHER THAN THOSE RECOMMENDED BY MIMAKI ENGINEERING MAY RESULT IN FIRE OR ACCIDENTS. SUCH INCIDENTS ARE NOT COVERED BY THE PRODUCT WARRANTY. MIMAKI ENGINEERING REJECTS ALL LIABILITY FOR DAMAGE, DIRECT OR INDIRECT, ARISING FROM SUCH INCIDENTS.
- USE ONLY GENUINE MIMAKI ENGINEERING INK AND MAINTENANCE LIQUID. USE OF OTHER PRODUCTS MAY RESULT IN FAILURES OR REDUCE PRINT QUALITY. SUCH INCIDENTS ARE NOT COVERED BY THE PRODUCT WARRANTY. MIMAKI ENGINEERING REJECTS ALL LIABILITY FOR DAMAGE, DIRECT OR INDIRECT, ARISING FROM SUCH INCIDENTS.
- DO NOT ATTEMPT TO REFILL THE INK BOTTLES WITH UNAUTHORIZED INK. SUCH INCIDENTS ARE NOT COVERED BY THE PRODUCT WARRANTY. MIMAKI ENGINEERING REJECTS ALL LIABILITY FOR DAMAGE, DIRECT OR INDIRECT, ARISING FROM SUCH INCIDENTS.
- USE ONLY GENUINE MIMAKI ENGINEERING ANTI FREEZING LIQUID. USE OF OTHER ANTI FREEZING LIQUID MAY CAUSE FAILURES OR REDUCE PRINT QUALITY. SUCH INCIDENTS ARE NOT COVERED BY THE PRODUCT WARRANTY. MIMAKI ENGINEERING REJECTS ALL LIABILITY FOR DAMAGE, DIRECT OR INDIRECT, ARISING FROM SUCH INCIDENTS.
- AVOID USING UV-LED UNITS OR UV POWER SUPPLY UNITS OTHER THAN THOSE SPECIFIED BY MIMAKI ENGINEERING. USING DEVICES OTHER THAN GENUINE MIMAKI ENGINEERING DEVICES MAY RESULT IN FAILURE, ELECTRIC SHOCK, OR FIRE. SUCH INCIDENTS ARE NOT COVERED BY THE PRODUCT WARRANTY. MIMAKI ENGINEERING REJECTS ALL LIABILITY FOR DAMAGE, DIRECT OR INDIRECT, ARISING FROM SUCH INCIDENTS.

# To Ensure Safe Use

## Symbols

In this document, symbols are used to indicate various precautions for operation. Make sure you fully understand the meaning of each symbol to ensure you use the machine safely and correctly.

Explanation		
 <b>WARNING</b>	Warning	Indicates a potential hazard that may result in death or serious injury if handled improperly or if instructions are disregarded.
 <b>CAUTION</b>	Caution	Indicates a potential hazard that may result in minor or moderate injury if handled improperly or if instructions are disregarded.
 <b>NOTICE</b>	Notice	Indicates a potential hazard that may result in property damage if handled improperly or if instructions are disregarded.
	Warning sign	Indicates something that requires attention. Warning specifics are drawn inside the symbol.
	Mandatory action sign	Indicates an action that must be carried out. The specifics of the mandatory action are drawn inside the symbol.
	Prohibition sign	Indicates a prohibited action. The specifics of the prohibited action are drawn inside the symbol.
 <b>Important!</b>	Important	Indicates important information related to use of this machine.
	Tip	Indicates useful reference information.
	Reference information	Indicates the corresponding page for related information.

# Maintenance

To ensure years of precise performance, maintain the machine periodically based on frequency of use. Read the maintenance precautions thoroughly before maintaining this product.

# 1. Maintenance Precautions



- This machine includes parts that must be replaced periodically. We therefore recommend taking out a maintenance contract. Carry out maintenance periodically and replace consumable items to prevent quality defects and accidents.

## ⚠ WARNING



- Clean periodically. Debris and dust will accumulate on electrical components when the machine is used for extended periods. There is a risk of failure, electric shock, or fire due to current leakage.
- Do not clean by blowing—e.g., avoid using air blowers. Doing so may lead to failure, electric shock, or fire involving the machine if airborne debris or dust gets inside electrical components. Wipe using a soft cloth soaked in diluted neutral detergent and thoroughly wrung out. A vacuum cleaner may also be used for cleaning.



- Be careful to prevent liquids from getting inside the machine. Otherwise there is a risk of failure, electric shock, or fire.

## ⚠ CAUTION



- The UV-LED unit becomes extremely hot. Be careful not to touch the LED after it has been turned off until it has sufficiently cooled.



- For heavy soiling, wipe using a soft cloth soaked in diluted neutral detergent and thoroughly wrung out.



- Pay close attention to ventilation and be sure to wear safety glasses, gloves, and a mask when handling ink, maintenance liquid, waste ink, or other solutions used with the machine. Leaking ink may adhere to the skin or get into the eyes or mouth.



## NOTICE



- Never touch the print head nozzle surface. Do not allow water or alcohol to come into contact with the print nozzle surface. This will increase the risk of machine failure or ejection failures (e.g., nozzle clogging or deflection).
- Do not use cotton swabs to clean around the head or carriage. Fibers from cotton swabs may adhere to the head nozzle surface and lead to ejection failures (e.g., nozzle clogging or deflection).
- Do not splash ink or maintenance liquid on the covers. Exposure to splashing ink or maintenance liquid may damage or deform the cover.
- Do not use benzine, thinner, or any chemical agent containing abrasives. Use of these chemicals may result in damage to or deformation of parts.
- Do not move the carriage by hand. To move the carriage, use the carriage out function on the menu.

## 2. Maintenance Timing

Timing	Item
At the end of the work day	Clean the wiper and wiper bracket.  <a href="#">"Wiper Cleaning"(P. 8)</a>
	Clean the wiper cleaner.  <a href="#">"Wiper Cleaning"(P. 8)</a>
	Clean the cap rubber.  <a href="#">"Cap Rubber Cleaning"(P. 10)</a>
	Clean the NCU.  <a href="#">"NCU Cleaning"(P. 11)</a>
	Clean the underside of the UV-LED lamp.  <a href="#">"Carriage Underside Cleaning"(P. 12)</a>
	Clean the underside of the carriage.  <a href="#">"Carriage Underside Cleaning"(P. 12)</a>
At the end of the work week	Clean the waste ink draining channel.  <a href="#">"Waste Ink Draining Channel Cleaning"(P. 14)</a>
	Clean the area around the station.  <a href="#">"Station Area Cleaning"(P. 10)</a>
	Clean the table.  <a href="#">"Table Cleaning"(P. 15)</a>
	Clean the cover and Y-bar.  <a href="#">"Exterior Cleaning (e.g., cover, Y-bar, )" (P. 15)</a>
	Check the waste ink levels in the waste ink tank.
Periodically	Shake the Ink bottle.  <a href="#">"Ink Maintenance"(P. 8)</a>

### Tools Required for Maintenance

To order replacement consumable items, contact your local dealer or our service office. For more information on consumable items, refer to our website. <https://mimaki.com/supply/inkjet.html>



- Do not store consumable items in locations where children may enter.

# 3. Performing Maintenance

## Ink Maintenance

If ink constituents are sedimented, the ink density may become uneven. We recommend shaking the Ink bottle periodically to keep printing consistent.

UV ink: once a month.

White ink: once a day.

### ● Shaking the Ink bottle

#### 1 Shake the Ink bottle to the left and right slowly at least 20 times.

- Tighten the ink bottle lid securely, then shake the bottle slowly from left to right to ensure that the ink moves inside, holding the ink bottle lid with a paper towel.

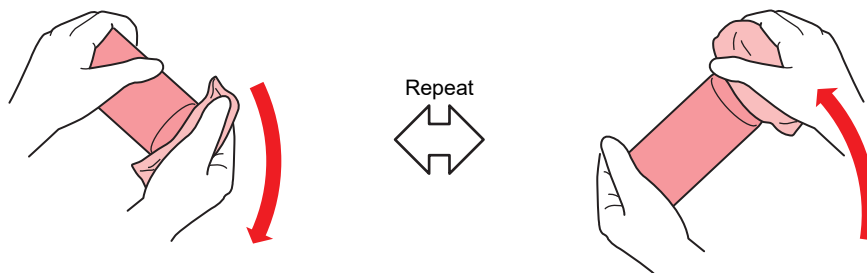

- Shake slowly. If the bottle is shaken too violently, ink may leak out or the air mixed in the ink may cause nozzle clogging.
- If the ink bottle is partially used, tilt it slowly until the ink bottle is upright.

## Wiper Cleaning

The wiper wipes off ink adhering to the print head nozzle surface. Continuing to use the dirty wiper may cause the wiper to which dried ink and dust are attached to rub against the nozzle surface, leading to printing defects (e.g., nozzle clogging or deflection).



- Be careful to avoid leaving fragments from the cleaning stick behind when cleaning. These fragments will increase the risk of ejection failures (e.g., nozzle clogging or deflection).

#### 1 From MENU on the touch panel, tap [MAINTENANCE].

- The Maintenance menu is displayed.

#### 2 Tap [Daily maintenance] > [Daily station maintenance].

- The carriage moves over the table.



### 3 Remove the wiper.

- Hold the lugs on both sides of the wiper bracket, then pull out the wiper.

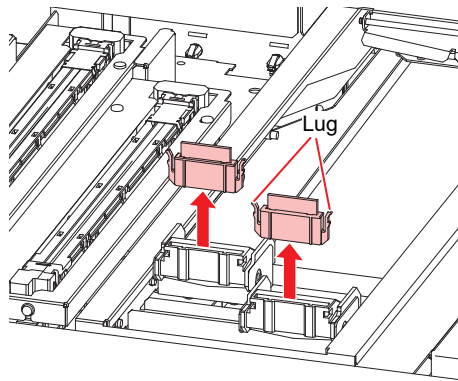

### 4 Clean the wiper and bracket.

- Wipe off any ink and dust adhering using a cleaning stick moistened with maintenance liquid. Wipe off the maintenance liquid. Make sure none remains.

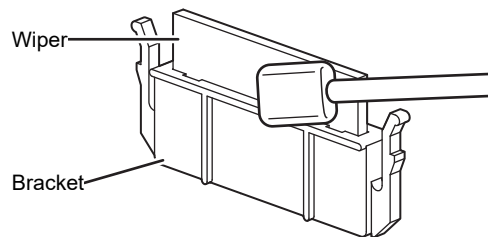

- Replace dirty or warped wipers with new ones.  ["Wiper Replacement"\(P. 17\)](#)

### 5 Clean the wiper cleaner.

- Wipe off any ink and dust adhering using a cleaning stick moistened with maintenance liquid. Wipe off the maintenance liquid. Make sure none remains.

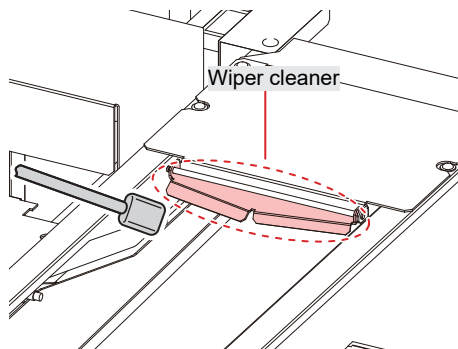

## 6 Reattach the wiper at the original position.

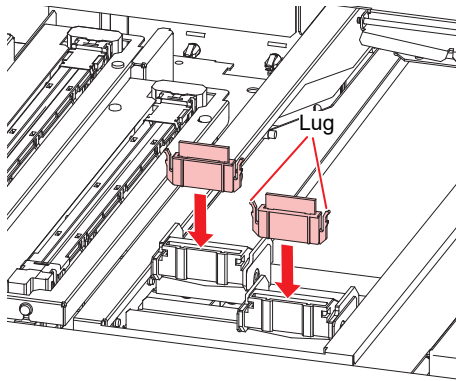

## 7 Tap [Complete] > [Finish] once cleaning is complete.

### Cap Rubber Cleaning

The cap rubber keeps the print head nozzle surface from drying out. Continuing to use a dirty cap may affect ink take-up and lead to ejection failures (e.g., nozzle clogging, deflection).



- Be careful to avoid leaving fragments from the cleaning stick behind when cleaning. These fragments will increase the risk of ejection failures (e.g., nozzle clogging or deflection).

#### 1 From MENU on the touch panel, tap [MAINTENANCE].

- The Maintenance menu is displayed.

#### 2 Tap [Daily maintenance] > [Daily station maintenance].

- The carriage moves over the table.

#### 3 Clean the cap rubber.

- Wipe off any ink and dust adhering using a cleaning stick moistened with maintenance liquid. Wipe off the maintenance liquid. Make sure none remains.

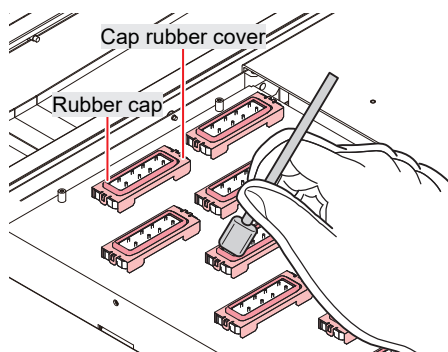

#### 4 Tap [Complete] > [Finish] once cleaning is complete.

### Station Area Cleaning

Continued use when dirty may prevent ink from flowing into the waste ink tank or cause dried ink and attached dust to rub against the head nozzle surface, leading to ejection failures (e.g., nozzle clogging, deflection).

**1** From MENU on the touch panel, tap [MAINTENANCE].

- The Maintenance menu is displayed.

**2** Tap [Weekly maintenance] > [Weekly station maintenance].

- The carriage moves over the table.

**3** Clean the wiper tray.

- Wipe off any ink and dust adhering using a cleaning stick moistened with maintenance liquid. Wipe off the maintenance liquid. Make sure none remains.
- Scrape off any dried ink with a spatula or similar tool.

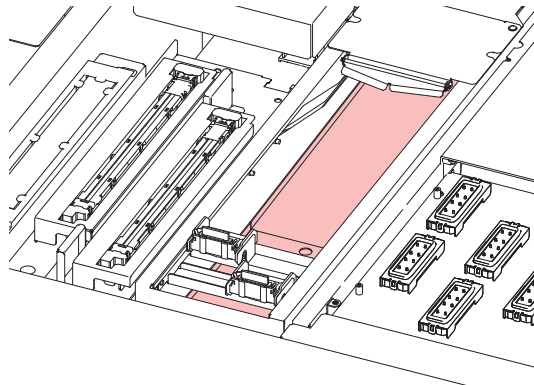
**4** Clean around the flushing filter and on the shutter surface.

- Wipe off any ink and dust adhering using a cleaning stick moistened with maintenance liquid. Wipe off the maintenance liquid. Make sure none remains.
- Scrape off any dried ink with a spatula or similar tool.

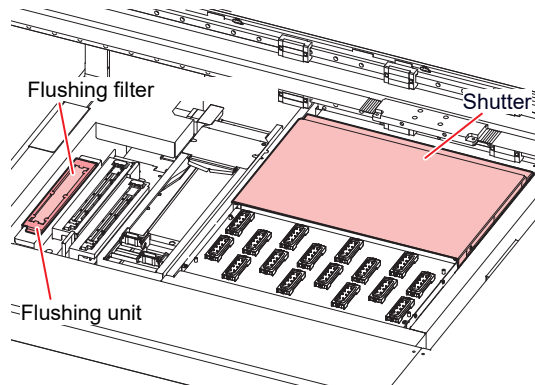

- If the flushing filter is exceptionally dirty, replace it with new one. 🖱️ ["Flushing Filter Replacement"\(P. 19\)](#)

**5** Tap [Complete] > [Finish] once cleaning is complete.**NCU Cleaning**

The NCU uses a sensor to monitor the ink droplets ejected from the print head nozzles. Continuing to use the dirty NCU may prevent the nozzle check function from operating correctly.



- Be careful to avoid leaving fragments from the cleaning stick behind when cleaning. These fragments will increase the risk of ejection failures (e.g., nozzle clogging or deflection).

**1** From MENU on the touch panel, tap [MAINTENANCE].

- The Maintenance menu is displayed.

**2** Tap [Daily maintenance] > [Daily station maintenance].

- The carriage moves over the table.

**3** Clean the NCU.

- Wipe off any ink and dust adhering using a cleaning stick moistened with maintenance liquid. Wipe off the maintenance liquid. Make sure none remains.

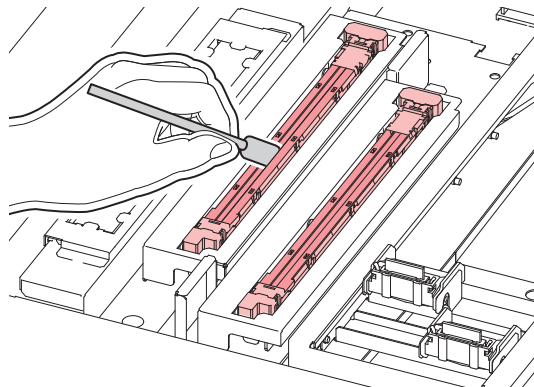

- Insert the cleaning stick as far as the line shown in the illustration.

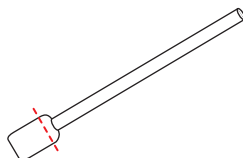

**4** Tap [Complete] > [Finish] once cleaning is complete.

## Carriage Underside Cleaning

The underside of the carriage becomes coated with ink wiped off by the wiper. Continuing to use the dirty carriage underside will rub dried ink and attached dust on to the media, resulting in contaminated prints.

The print head uses an extremely delicate mechanism. Take great care when handling it.



- Be careful to avoid leaving fragments from the cleaning stick behind when cleaning. These fragments will increase the risk of ejection failures (e.g., nozzle clogging or deflection).

**1** From MENU on the touch panel, tap [MAINTENANCE].

- The Maintenance menu is displayed.

**2** Tap [Daily maintenance] > [Head maintenance].

- The carriage moves to the maintenance space.

### 3 Slide the maintenance cover on the left side of the Y-bar.

- Lift the lever and slide it to the left.

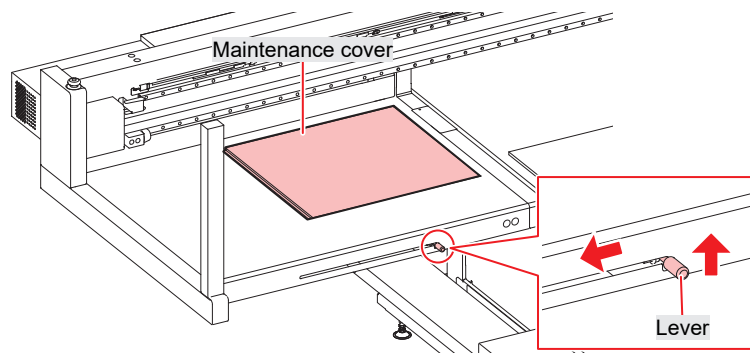

### 4 Clean the UV-LED lamp.

- Wipe off any ink and dust adhering using a cleaning stick moistened with maintenance liquid. Wipe off the maintenance liquid. Make sure none remains.

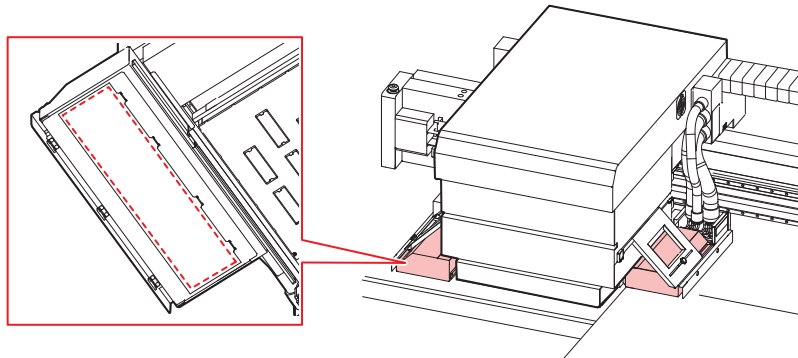

- Do not use excessive force when rubbing the UV-LED lamp with a cleaning stick. The UV-LED lamp may be damaged.

### 5 Clean around the print head.

- Wipe off any ink and dust adhering using a cleaning stick moistened with maintenance liquid. Wipe off the maintenance liquid. Make sure none remains.

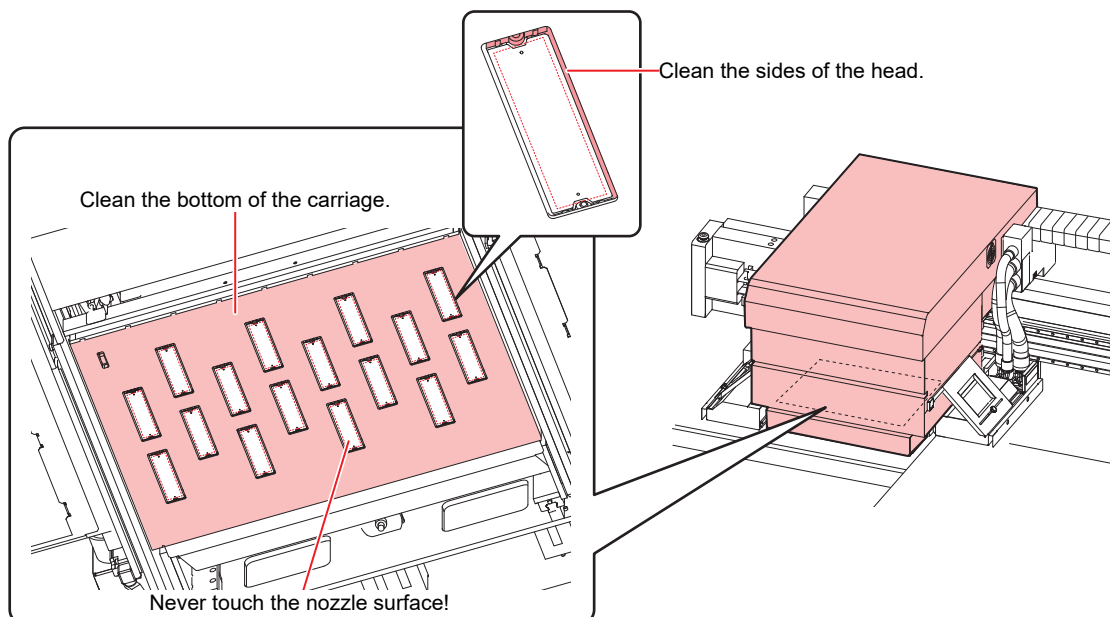



- Never touch the print head nozzle surface.

- 6 Once cleaning is complete, slide the maintenance cover on the left side of the Y-bar to close it.

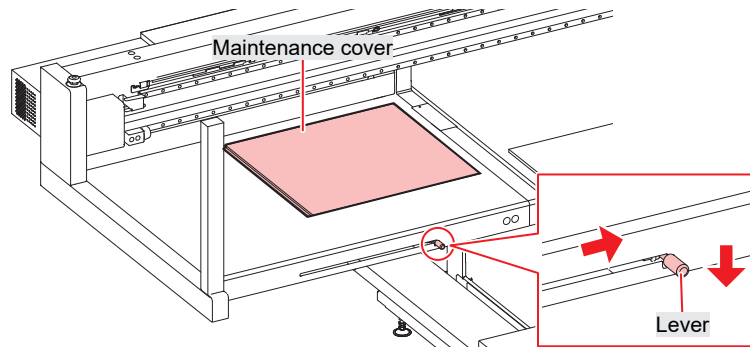

- Make sure the maintenance cover is returned to the correct position.

- 7 Tap [Complete] > [Finish].

## Waste Ink Draining Channel Cleaning

Clean the ink discharge channel regularly to prevent clogging of the ink discharge channel below the cap.

- 1 From MENU on the touch panel, tap [MAINTENANCE].
  - The Maintenance menu is displayed.
- 2 Tap [Weekly maintenance] > [Clean ink discharge path].
  - The carriage moves over the table.
  - The suction pump will start operating.
- 3 Apply maintenance liquid to the caps.
  - Use a syringe to draw up and apply maintenance liquid to the caps.

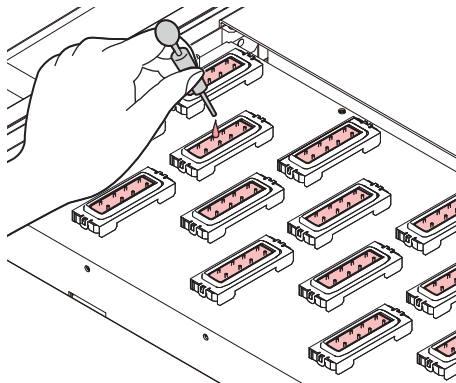

- 4 Tap [Complete].
  - Maintenance liquid is discharged from the pump tube (waste ink draining channel below the cap). The carriage returns to the station.

## Table Cleaning

Continuing to use the dirty table will cause dried ink and attached dust to rub against the head nozzle surface, resulting in ejection failures (e.g., nozzle clogging, deflection). Ink left adhering to the table for extended periods will be hard to remove, even with ethanol or solvents.



- Turn off the main power before performing maintenance tasks.

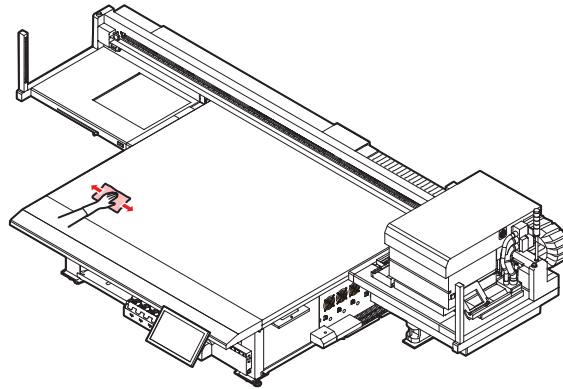

Remove dust or any solid materials frequently, using soft brush, dry cloth, or paper towel.

Dust and debris will accumulate on parts such as the table grooves and screw holes. Use a soft bristle brush to remove dust and debris.



- For heavy soiling, wipe using a soft cloth soaked in diluted neutral detergent and thoroughly wrung out.



- Be careful to prevent liquids from getting inside the machine. Otherwise there is a risk of failure, electric shock, or fire.

## Exterior Cleaning (e.g., cover, Y-bar, )



- Turn off the main power before performing maintenance tasks.

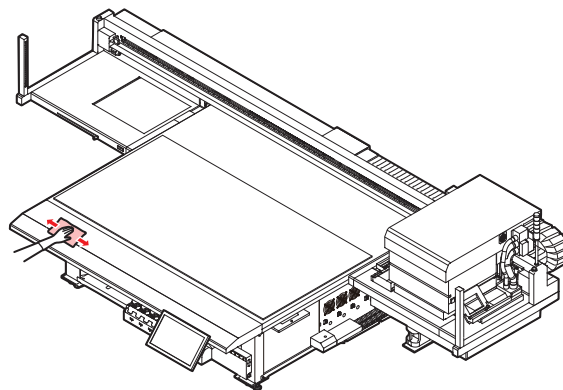

- For heavy soiling, wipe using a soft cloth soaked in diluted neutral detergent and thoroughly wrung out.



- Be careful to prevent liquids from getting inside the machine. Otherwise there is a risk of failure, electric shock, or fire.

#### LM Guide

---

Wipe off dust from the left and right ends of the LM guide surface with a soft dry cloth.

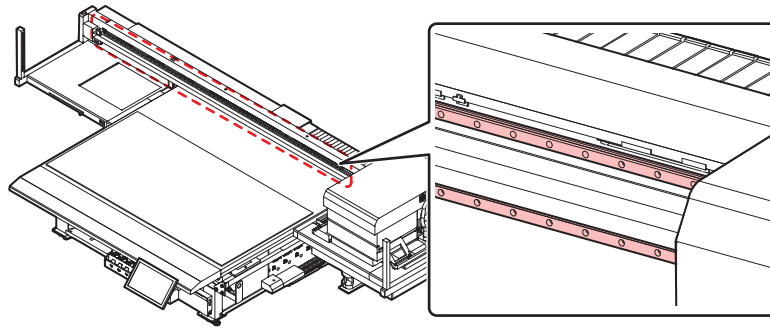

---

**Important!**

- The LM guide is lubricated. Never wipe with solvents such as ethanol. Wipe off any excess or dripping lubricant with a soft dry cloth.
-



# 4. Consumable Item Replacement

To order replacement consumable items, contact your local dealer or our service office.

For more information on consumable items, refer to our website. <https://mimaki.com/supply/inkjet.html>



- Do not store consumable items in locations where children may enter.



- When disposing of consumable items, contact an industrial waste disposal operator or dispose of the product in accordance with the local laws and regulations.

## Wiper Replacement

The machine maintains a count of the number of wiping cycles. Once the specified value is reached, "0605 REPLACE WIPER" will appear in SYSTEM ALARM on the touch panel. Replace dirty or warped wipers with new ones.

- 1 From MENU on the touch panel, tap [MAINTENANCE].**
  - The Maintenance menu is displayed.
- 2 Tap [Replace parts] > [Replace wiper].**
  - The carriage moves over the table.
- 3 Remove the wiper.**
  - Hold the lugs on both sides of the wiper bracket, then pull out the wiper.

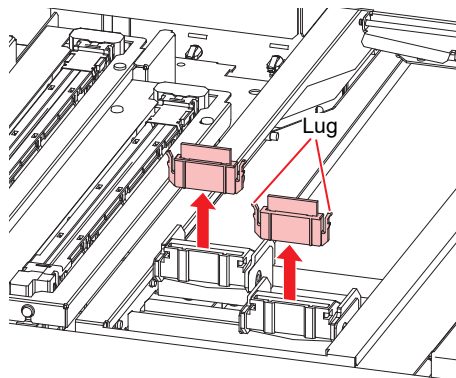

- 4 Clean the wiper cleaner.**
  - "Wiper Cleaning"(P. 8)

**5** Mount a new wiper.

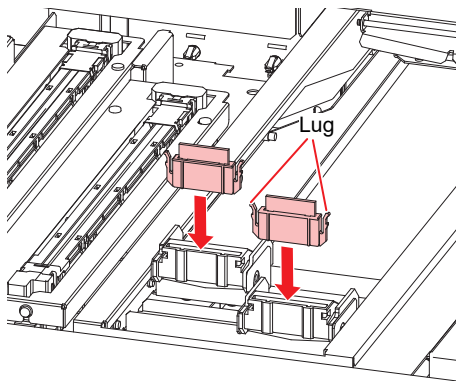

**6** Tap [Complete] > [Finish] once replacement is complete.

- The wiper usage count is reset.

## Carriage Filter Replacement

Check the mist filters and replace if very dirty.



- Turn off the main power before performing maintenance tasks.

**1** Remove the carriage filter covers.

- Remove the screws, then remove the filter covers.

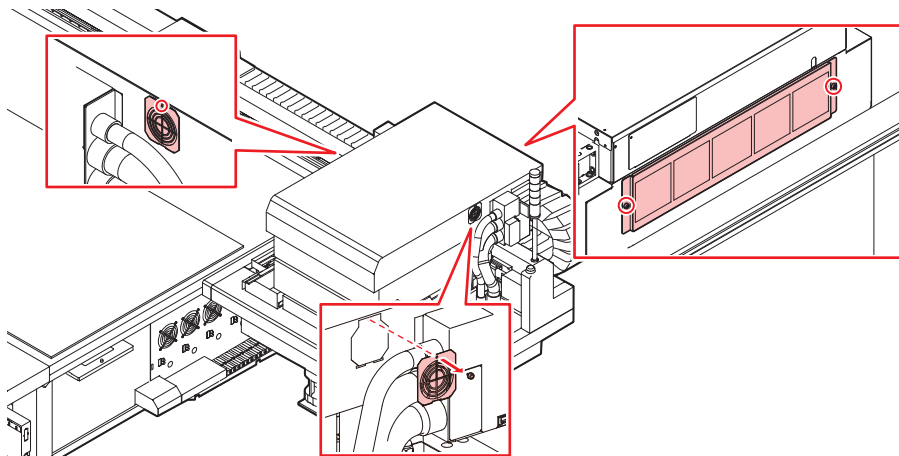

- Filters are positioned on the left, right, and back of the carriage.

**2** Install new filters.

**3** Install the filter covers.

- Left and right of carriage: Fit the tabs on the bottom of the filter cover to the carriage cover, then secure with screws.
- Back of carriage: Be careful to avoid dropping the filter cover.

## Flushing Filter Replacement

The machine counts the amount of ink used in flushing. When a specified value is reached, SYSTEM ALARM will appear on the touch panel. Use this as a guide for replacing the flushing filter.

**1 From MENU on the touch panel, tap [MAINTENANCE].**

- The Maintenance menu is displayed.

**2 Tap [Replace parts] > [Replace flushing filter].**

- The carriage moves over the table.

**3 Remove the flushing filter.**

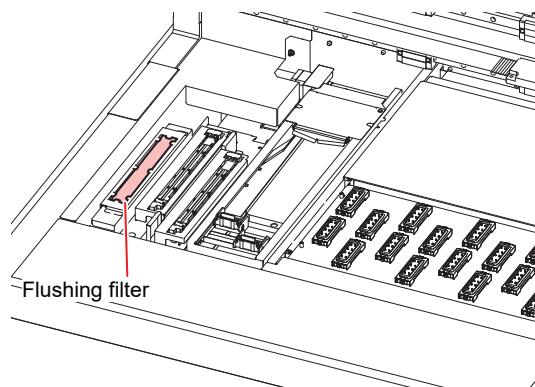

**4 Clean around the flushing filter.**

-  ["Station Area Cleaning"\(P. 10\)](#)

**5 Install a new flushing filter.**

**6 Tap [Complete] > [Finish] once replacement is complete.**

- This resets the ink flushing amount.

## NCU Ink Pad Replacement

If the NCU ink pad must be replaced, "0657 Check NCU waste ink" will appear in SYSTEM ALARM on the touch panel. Use this as a guide for replacement.

**1 From MENU on the touch panel, tap [MAINTENANCE].**

- The Maintenance menu is displayed.

**2 Tap [Replace parts] > [Replace NCU absorbent].**

- The carriage moves over the table, and the station rises.

### 3 Remove the NCU ink-receiving pan.

- Slide forward to remove.

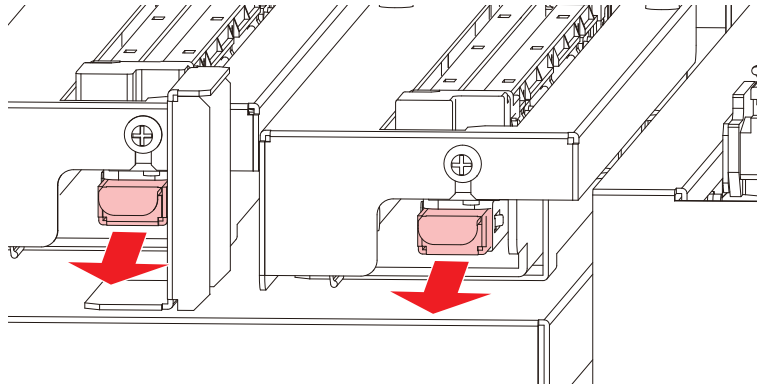

### 4 Remove the ink pad from the NCU ink-receiving pan.

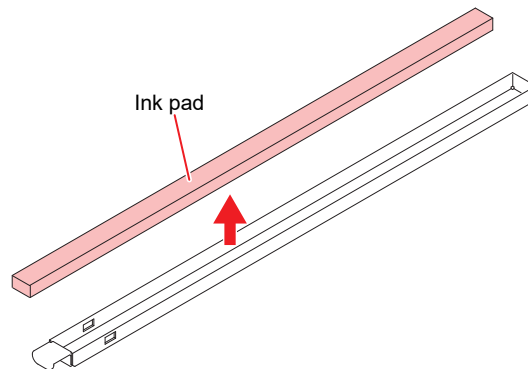

### 5 Clean the NCU ink-receiving pan.

### 6 Install a new NCU ink pad.

### 7 Install the NCU ink-receiving pan.

- Insert until it clicks into place, and confirm that the tabs are engaged.

### 8 Tap [Complete] > [Finish] once replacement is complete.

- This resets the NCU ink pad count.

## Bottle Ink Wipe Filter Replacement

Check the bottle ink wipe filters and replace if very dirty.

### 1 Remove the wipe filters.

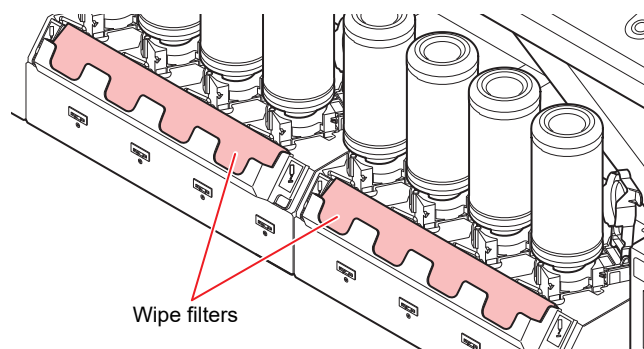

**2** Clean the wipe filter case.

**3** Install new wipe filters.

## Waste Ink Tank Replacement

Ink used during head cleaning and other processes is collected in the waste ink tank at the lower right of the machine.

The machine uses a sensor to monitor the waste ink tank weight. When the weight sensor reacts, "0666 WASTE INK TANK FULL" will appear in SYSTEM ALARM on the touch panel. If this alarm appears, replace the waste ink tank. The machine also counts the amount of ink discharged. Once the discharge amount reaches a specified value, "0604 CHECK WASTE BOTTLE" will appear in SYSTEM ALARM on the touch panel. Use this a guide for replacing the waste ink tank.



- For a 2.6-liter tank, the preset level is 80% (2.1 liters).
- Continuing to use the product without disposing of the waste ink may result in waste ink overflowing from the waste ink tank. Although the machine uses a sensor to detect the waste ink amount, and displays the message prompting to replace the waste ink tank, visually check ink levels in the waste ink tank about once a week.



- Pay close attention to ventilation and be sure to wear safety glasses, gloves, and a mask when handling ink, maintenance liquid, waste ink, or other solutions used with the machine. Leaking ink may adhere to the skin or get into the eyes or mouth.



## Replacing the Waste Ink Tank

**1** From MENU on the touch panel, tap [MAINTENANCE].

- The Maintenance menu is displayed.

**2** Tap [Other maintenance] > [Replace waste ink tank].

**3** Open the waste ink tank guard.

- Remove the screw to open the waste ink tank guard.

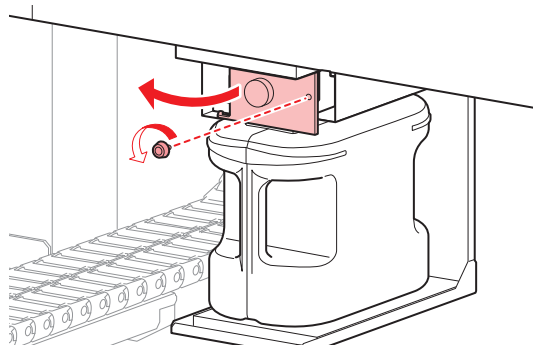

**4** Grasp the handle of the waste ink tank and slide out.

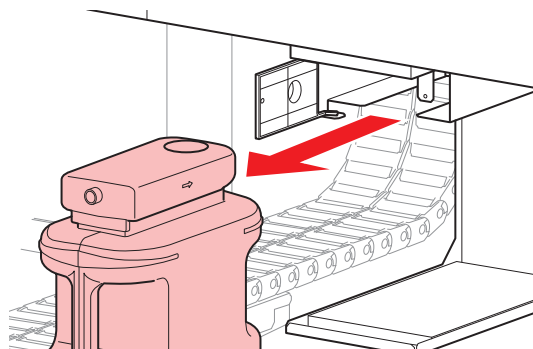

**5** Attach the cap to the removed waste ink tank, and use tape to prevent leakage of waste ink.

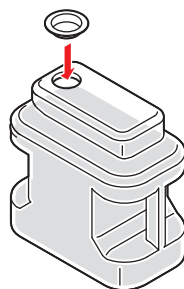

- When disposing of ink, maintenance liquid or other liquid used with the product, or the container or paper towel to which ink or other liquid is attached, contact an industrial waste disposal operator or dispose of the product in accordance with the local laws and regulations.

**6** Install a new waste ink tank.

**7** Close the waste ink tank guard.

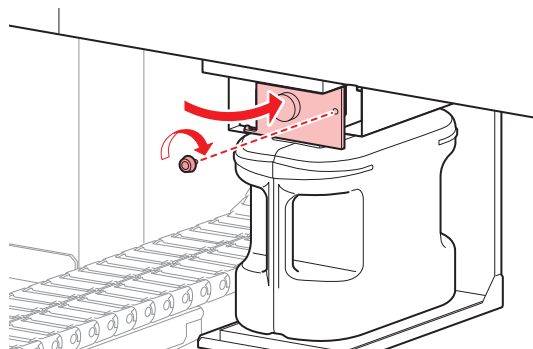

**8** Tap [Complete] > [Finish] once replacement is complete.

- The waste ink level will be reset.

## Refilling Cooling Water (Mixed With Antifreeze)

The UV-LED unit will become hot with use. Cooling water (mixed with antifreeze) is used to cool this unit. Once the specified value is reached, "0705 WATER LACK" will appear in SYSTEM ALARM on the touch panel, and a buzzer will sound. Refill the cooling unit tank with cooling water mixed with antifreeze (1 part antifreeze to 2 parts water). Filling requires about 830 ml of the antifreeze mixture per tank.



- Use only genuine Mimaki Engineering anti freezing liquid. Use of other anti freezing liquid may cause failures of the cooling unit.
- Take care to prevent any potential sources of ignition such as sparks caused by static electricity or material impacts.
- Be sure to dispose of any unneeded anti freezing liquid in the following manner.
  - (1) Soak it up with materials such as sawdust or rags and burn them in an incinerator.
  - (2) Pass them onto a licensed industrial waste disposal company after clearly indicating their contents.

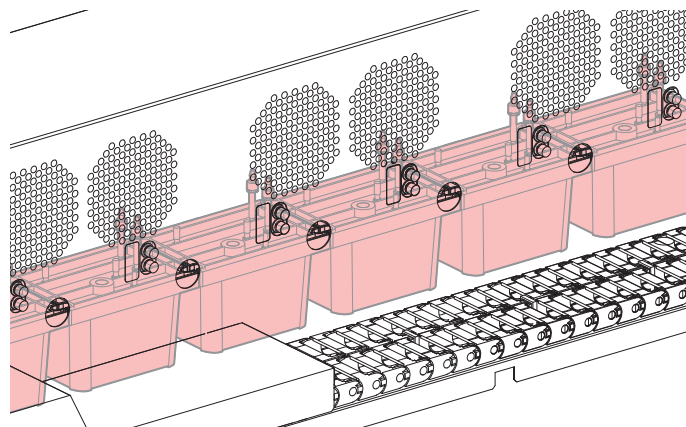

## 1 Combine 1 part antifreeze to 2 parts water in the container (provided).



- Antifreeze mixture precautions
  - (1) Be sure to use water that satisfies the following conditions.
    - Calcium content: Not exceeding 10 mg/L (1 mg/100 ml)
    - Hardness: Not exceeding 60 mg/L
    - Distilled or purified water
  - (2) Do not use antifreeze mixture that has been prepared far in advance.
  - (3) Any excess antifreeze mixture must be used within one week. Filling the machine with antifreeze mixture that has been prepared more than one week in advance may lead to a malfunction.

## 2 Transfer the antifreeze mixture to the syringe (provided).



## 3 From MENU on the touch panel, tap [MAINTENANCE].

- The Maintenance menu is displayed.

## 4 Tap [Other maintenance] > [Refill cooling water].

- A dialog box appears.



- During touch panel operation, the Y-bar will move to the front of the table. Do not approach the machine until the Y-bar has come to a complete stop.

### 5 Remove the caps for water supply and air purging.

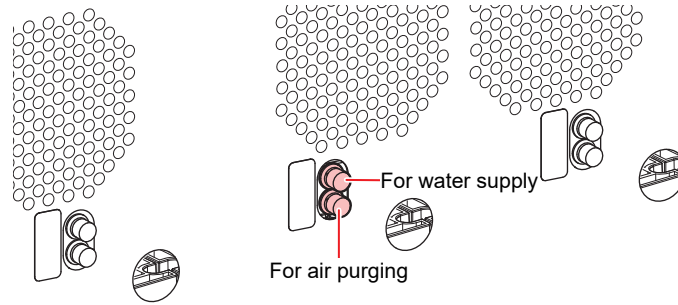

### 6 Inject the mixture of water and antifreeze.

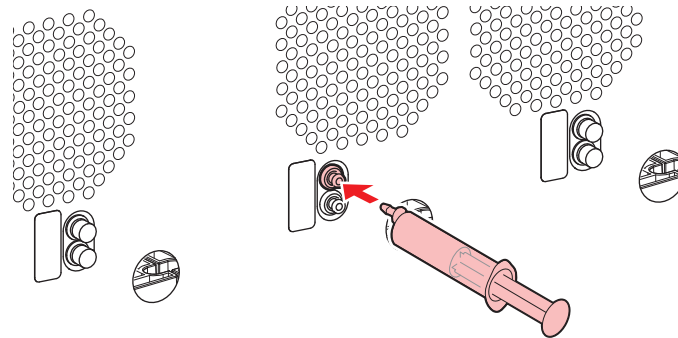

- The buzzer will stop after you inject about 400 ml of the mixture into each tank.

### 7 After the buzzer stops, inject an additional 430 ml of the mixture into each tank.



- Do not inject more than 430 ml of additional mixture. Injecting more may cause the tank to overflow.

### 8 After injection is finished, replace the caps.







## **Care and maintenance**

---

---

March, 2024

**MIMAKI ENGINEERING CO.,LTD.**

2182-3 Shigeno-otsu, Tomi-shi, Nagano 389-0512 JAPAN

---

---

D203595-12-18032024

